

## MINIMAN-100

### EXTRACTION ARM

The MiniMan-100 is a compact flexible arm, which is ideal for all types of smaller dust and fume applications.

The arm is fitted with exterior friction joints. The inner tubes are kept in place by a gas spring (standing arm) or a balancing strap (hanging arm). This design ensures smooth movement of the arm.

The MiniMan-100 arm is available in different versions, including ATEX<sup>1</sup>. The specific TopGrade arms have a distinctive colour and are meant for use in clean working environments, such as laboratories.

<sup>1</sup> Approved for use in explosive environments zone 1 and 21; marking Ex II 2G 2D (in accordance with TRGS 727 & ATEX Directive 2014/34/EU)



Image: MiniMan type MM-100-2.1/H

### APPLICATIONS

The standard MiniMan-100 arm (yellow) is intended to be used for the following applications: 

- soldering fumes
- airborne dust
- fumes from solvents
- TIG welding
- MIG-MAG/GMAW welding

The MiniMan-100 TopGrade arm (fully white) is especially suitable for use in laboratories in the pharmaceutical, chemical and food processing industry. 

### SPECIFICATIONS

#### Physical dimensions and properties

Diameter	Ø 100 mm (4 in.)	
Material of tubes	aluminium	
Colour:	standard arm	TopGrade
• tubes	• yellow RAL 1004	• white RAL 9010
• hoses	• black	• white

#### Performance

Recommended airflow	200-450 m <sup>3</sup> /h (118-265 CFM)
• min. airflow	• 200 m <sup>3</sup> /h (118 CFM)

#### Conditions of storage and use

Process temperature:	<ul style="list-style-type: none"> <li>• min. 5°C (41°F)</li> <li>• nom. 20°C (68°F)</li> <li>• max. 70°C (158°F)</li> </ul>
Max. relative humidity	90%
Suitable for outdoor use	no
Storage conditions	<ul style="list-style-type: none"> <li>• 5-45°C (41-113°F)</li> <li>• relative humidity max. 80%</li> </ul>

#### Options and accessories

DAMPER-100	shut-off valve
<b>MiniMan-100 all types (except for ATEX versions):</b>	
S-100	manual on/off switch for hood mounting
LL-5.5/24-100 + TR-24	manual on/off switch, incl. working light; transformer 230/24V

#### Product combinations

PA-110/160   PA-220/160	stanchion + ducting
Extraction fan:	suitable for:
• FUA-2100	• 2-3 MiniMan arms
• FUA-3000	• 3-4 MiniMan arms
• FUA-4700	• 4-5 MiniMan arms

#### Scope of supply

Extraction arm (fully assembled) | Mounting bracket

#### Order information

Number/package	1
----------------	---

#### Logistics data

Harmonized Tariff Code	84219990
------------------------	----------

### WORKING REACH

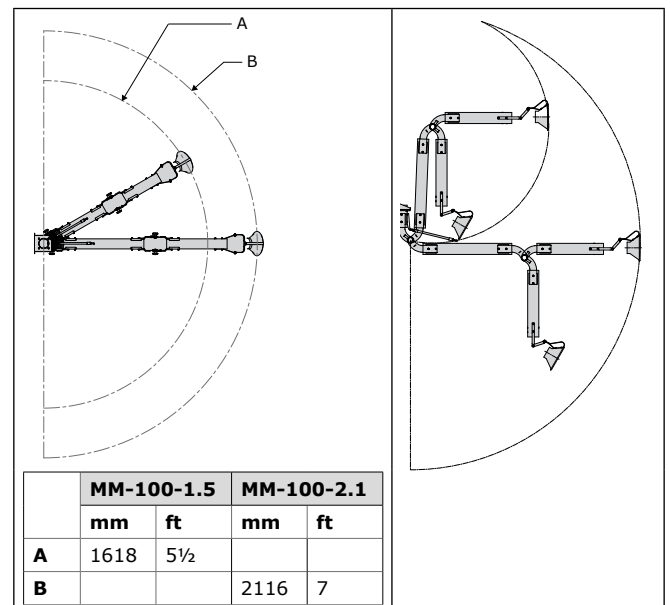

### ARM MOVEMENT

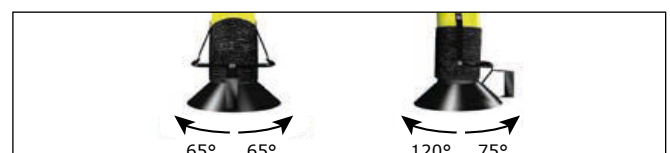

## Remaining specifications

Type	MM-100-1.5/H	MM-100-2.1/H	MM-100-1.5/H	MM-100-2.1/H	MM-100-1.5/S	MM-100-2.1/S
			ATEX	ATEX		
			Extraction arm in accordance with: TRGS 727 & ATEX directive 94/9/EC			
<b>Physical dimensions and properties</b>						
Material of hoses	PVC with internal steel spiral; flame-retardant		PVC with internal steel spiral; flame-retardant and antistatic		PVC with internal steel spiral; flame-retardant	
Mounting position	hanging	hanging	hanging	hanging	standing	standing
Length (nom.)	1,5 m (5 ft.)	2,1 m (7 ft.)	1,5 m (5 ft.)	2,1 m (7 ft.)	1,5 m (5 ft.)	2,1 m (7 ft.)
Weight (net)	9,5 kg (21 lbs.)	12 kg (26½ lbs.)	9,5 kg (21 lbs.)	12 kg (26½ lbs.)	9,5 kg (21 lbs.)	12 kg (26½ lbs.)
<b>Order information</b>						
Article no.:						
• yellow arm	0000101109	0000101110	0000101128	0000101129	0000114588	0000114587
• white arm (TopGrade)	0000101117	0000101118	-	-	-	-
<b>Logistics data</b>						
Gross weight	10,5 kg (23 lbs.)	13 kg (28½ lbs.)	10,5 kg (23 lbs.)	13 kg (28½ lbs.)	10,5 kg (23 lbs.)	13 kg (28½ lbs.)
Packing dimensions	1200 x 400 x 300 mm (47 x 15¾ x 11¾ in.)	1600 x 500 x 300 mm (63 x 19½ x 11¾ in.)	1200 x 400 x 300 mm (47 x 15¾ x 11¾ in.)	1600 x 500 x 300 mm (63 x 19½ x 11¾ in.)	1200 x 400 x 300 mm (47 x 15¾ x 11¾ in.)	1600 x 500 x 300 mm (63 x 19½ x 11¾ in.)
Max. number/pallet	10	6	10	6	10	6

## MOUNTING EXAMPLES "H" TYPES

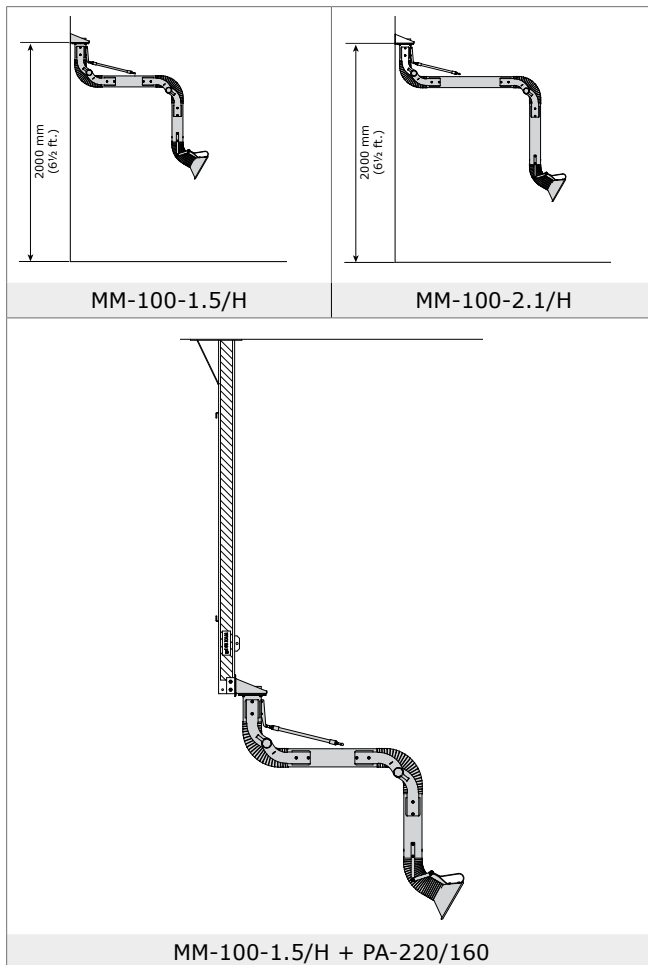

## MOUNTING EXAMPLES "S" TYPES

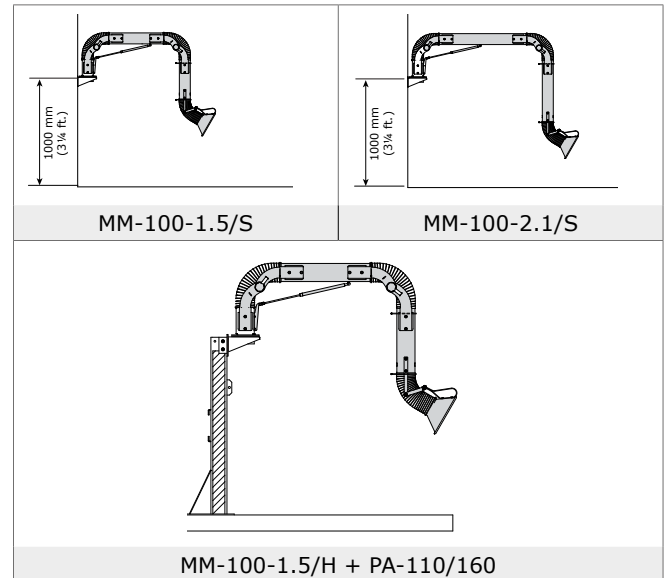

## PRESSURE DROP

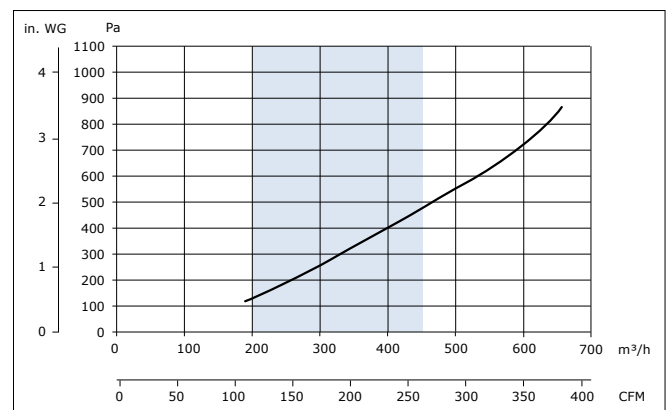

## FEATURES & BENEFITS

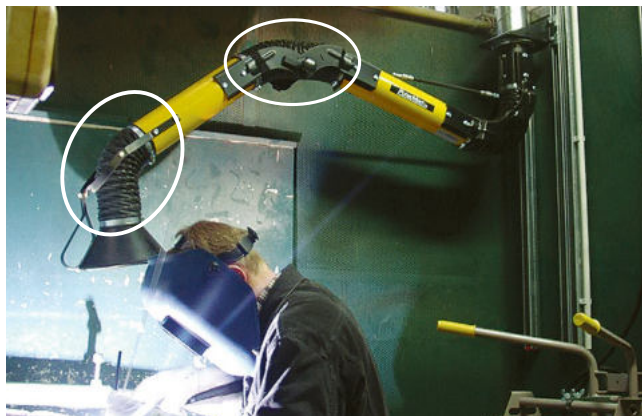

Exterior friction joints ("ClearThru" design), which allows for maximum air velocity, low pressure drop and low noise level

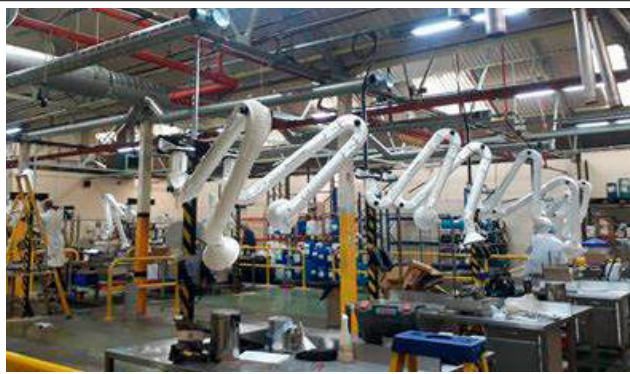

Special TopGrade version, especially for clean working environments

### Application restrictions

Do **not** use the product in combination with a filter for the following applications or in the following circumstances: polishing applications in combination with grinding, welding or any other application that generate sparks (fibres from polishing or abrasive flap disks are highly flammable and pose a high risk of filter fires when exposed to sparks) | aluminium laser cutting | oil mist | heavy oil mist in welding fume | arc-air gouging | extraction of aggressive fumes and gases (e.g. from acids, from alkaline, from soldering paste containing lithium) | extraction of hot gases (more than 70°C/158°F continuously) | grinding aluminum and magnesium | flame spraying | extraction of cement, saw dust, wood dust etc. | sucking cigarettes, cigars, oiled tissues and other burning particles, objects and acids | explosive environments or explosive substances/gases



Product type  
Article no.  
Product category  
Version

**MiniMan-100**  
*refer to Order information*  
extraction arms  
141222/B

Always check the latest version on [www.plymovent.com](http://www.plymovent.com)